



# CONSUMER AFFAIRS PRODUCT SAFETY WARNING

## Portable Soccer Goals

*This fact sheet has been prepared to warn consumers on some safety concerns with the use of portable soccer goals and provides some tips to assist Territory adults and children to play safe and stay safe when using portable soccer goals.*

*The deaths in Australia caused by portable soccer goals include;*

- A jogger jumped up and grabbed the crossbar to do a chin-up. The structure apparently toppled forward onto him crushing his chest to the ground – causing death;
- A young boy while playing handball in the goalmouth, other boys climbed onto the netting on the goal, the goal frame overbalanced and toppled onto the boy – causing death;
- A young boy was struck on the head by the crossbar that was accidentally pulled down onto him by an opposing player doing a chin-up – causing death;
- A 3 year old died when an unsecured portable soccer goal toppled over striking her on the head.

### Components of a moveable soccer goal

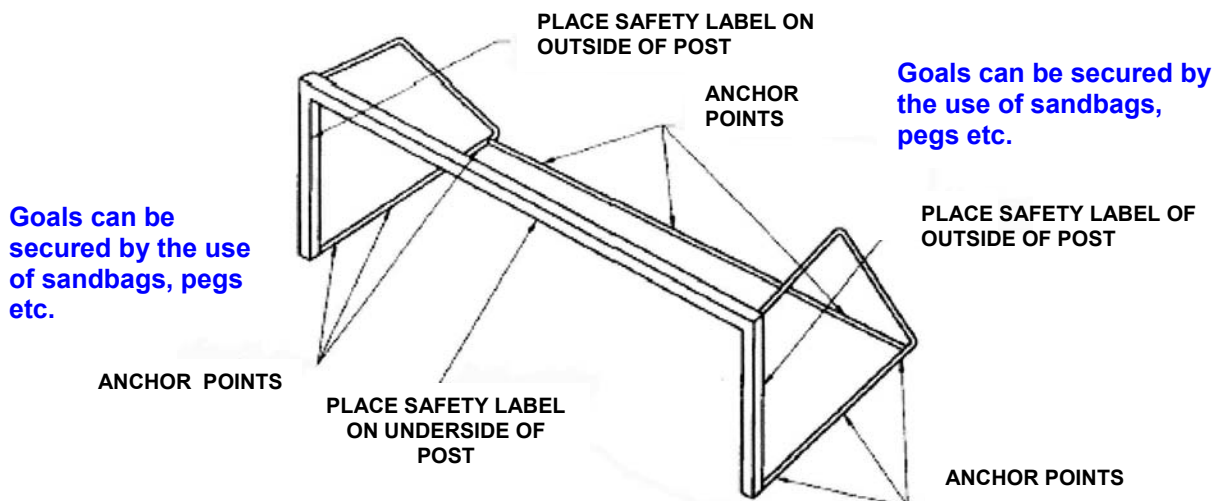

### PLAY SAFE – STAY SAFE

**ALWAYS** secure the goal & **NEVER** climb on the goal or netting or hang on the crossbar.

**UNSECURED GOALS MAY TIP OVER AND CAUSE SERIOUS INJURY OR DEATH**

*Check out the goal posts being used at your child's school, and your sporting arena.*

For further information contact either

or

**Mr Bill Miller Football Federation NT**  
Ph: 08 8941 2444 Mobile 0414 641 720  
Email: [ceo@footballnt.com.au](mailto:ceo@footballnt.com.au)

**Consumer Affairs Product Safety Officer**  
Ph: 08 8999 8984 or toll free 1800 019 319  
Email: [james.pickett@nt.gov.au](mailto:james.pickett@nt.gov.au)

**General Disclaimer:** The material contained in this publication is intended for use as a guide and for general information only. It is not intended to be a substitute for independent professional advice. The Northern Territory Department of Justice accepts no responsibility or liability for the correctness, accuracy and completeness of any of the material contained in this publication and recommends that users of this publication exercise their own skill, care and judgment in the application of the information contained in the publication